

## IMPLEMENTATION OF AUTOMATIC VOLTAGE REGULATORS ON REAL TIME TARGETS

**Cosmin Bucur, Paul Burlacu, Mihai Alexa**

*Ovidius University of Constantza  
Department of Mechanical Engineering  
Mamaia no.124, Constantza  
e-mail: bcmircea@univ-ovidius.ro*

### Abstract

Many different models have been developed to represent the various types used in a power system. The literature present various types of AVR (automatic voltage regulator) model, some more difficult to implement on real time targets than others. This paper presents those models and a software implementation in Labview, which can be used in simulating power systems.

### Keywords:

Labview, Real Time, Automatic Voltage Regulator, Hardware in the loop

### 1. INTRODUCTION

Implementing an automatic voltage regulator in real time targets is very important in the stage of testing of AVRs, and implementing hardware in loop system for AVR is an important task.

Automatic voltage regulator is part of the excitation system for synchronous generators. The block diagram for the excitation system is presented in fig1:

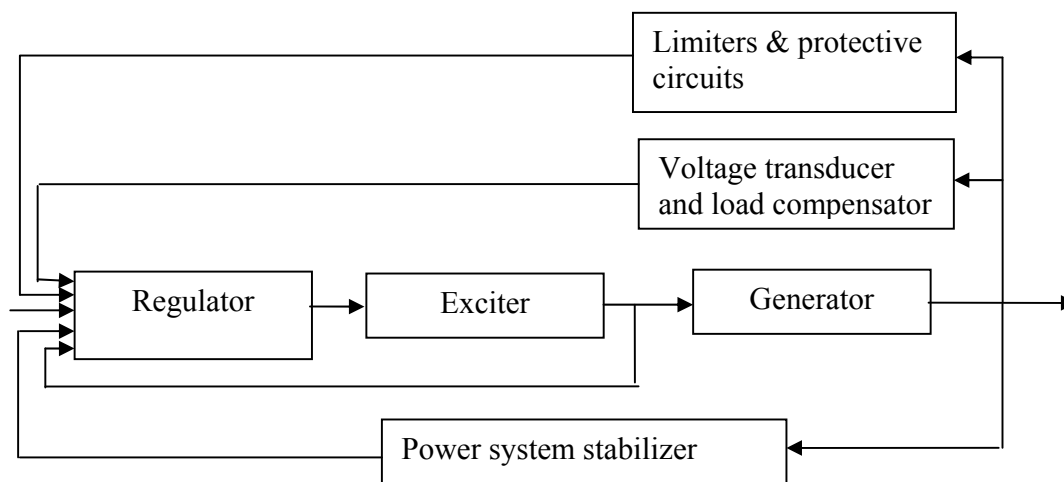

Fig 1

The exciter provides DC power to the synchronous machine. There are three types of exciter systems [1]:

- DC excitation systems (DC generator as source of excitation power)
- AC excitation systems (AC machines as source of excitation power)
- Static excitation systems (Controlled or uncontrolled static rectifiers supply the excitation current)

Regulator processes and amplifies input control signals to a level and form appropriate for control of the exciter.

Voltage transducer and load compensator senses generator terminal voltage, rectifies and filters it to DC quantity and compares it with the reference. Load compensation, in addition, may be provided if it is desired to hold constant voltage at some point electrically remote from the generator terminal.

Power System Stabilizer (PSS) provides additional input signal to the regulator to damp power system oscillations. (Typical input signals: Rotor speed deviation, accelerating power, frequency deviation).

Limiters and protective circuits provide control and protective functions which ensure that the capability limits of the exciter and generator are not exceeded.(Field current limiter, maximum excitation limiter, terminal voltage limiter, under-excitation limiter.)

## 2. EXCITATION SYSTEM MODEL

In modeling an excitation system the better approach is to develop a single general purpose AVR model, on a similar basis to the synchronous machine model. The model can revert to any desired type. Several types of exciter systems are defined by IEEE and one of such model are presented below [2], in fig 2:

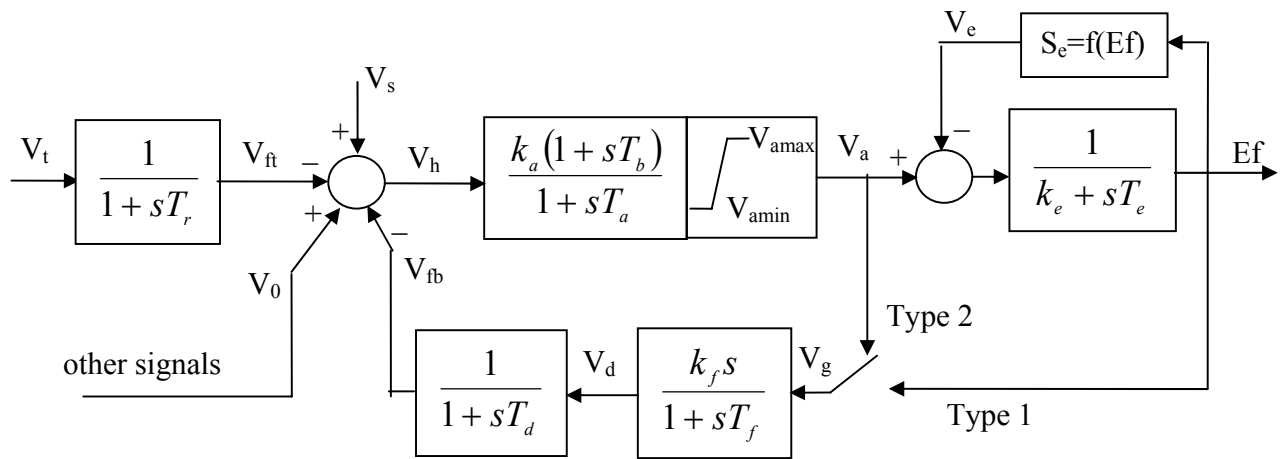

Fig 2

The equations for the AVR (Type 2) model are:

$$sV_{ft} = \frac{V_t - V_{ft}}{T_r} \quad (1)$$

$$sV_a = \frac{k_a (1 + sT_b)V_h - V_a}{T_a} \quad (2)$$

$$V_{a \max} \geq V_a \geq V_{a \min} \quad (3)$$

$$sE_f = \frac{V_a - V_e - k_e E_f}{T_e} \quad (4)$$

$$sV_d = \frac{k_f \cdot sV_g - V_d}{T_f} \quad (5)$$

where  $V_g = V_a$  for type 2, or  $V_g = E_f$  for type 1 AVRs.

$$sV_{fb} = \frac{V_d - V_{fb}}{T_d} \quad (6)$$

$$V_e = S_e E_f \quad (7)$$

Other signals can be signals from power system stabilizer or other auxiliary circuits.

The IEEE recommends that  $S_e$  be specified at maximum field voltage ( $S_{e \max}$ ) and at 0.75 of maximum field voltage ( $S_{e0.75}$ ). From this,  $S_e$  may be determined for any value of field voltage by either linear interpolation or by fitting a quadratic. Where linear interpolation is used equation (7) may be transformed to:

$$V_e = (k_1 E_f - k_2) E_f \quad (8)$$

where

$$k_1 = 4S_{e0.75 \max} / 3E_{f \max} \quad \text{if } E_f \leq 0.75E_{f \max}$$

$$k_2 = 0$$

or

$$k_1 = 4(S_{e \max} - S_{e0.75 \max}) / E_{f \max} \quad \text{if } E_f \geq 0.75E_{f \max}$$

$$k_2 = 4S_{e0.75 \max} - 3S_{e \max}$$

### 3. SOFTWARE IMPLEMENTATION

We will now illustrate a software implementation in Labview for use in test systems for AVRs. We choose Labview for implementation because of availability of real time hardware, so an implementation of hardware in the loop is easier. From the system model we choose the type 2 block diagram.

For the real time implementation the system should be composed from a data acquisition device for measuring the instantaneous bus bar voltage, a real time hardware type compact fieldpoint (National Instruments) for the implementation of virtual instrument, an actuator for feeding the excitation system.

In fig 3 we present the front panel for the AVR virtual instrument that we created for the implementation of the exciter system, and which we used for simulation of the type 2 AVR:

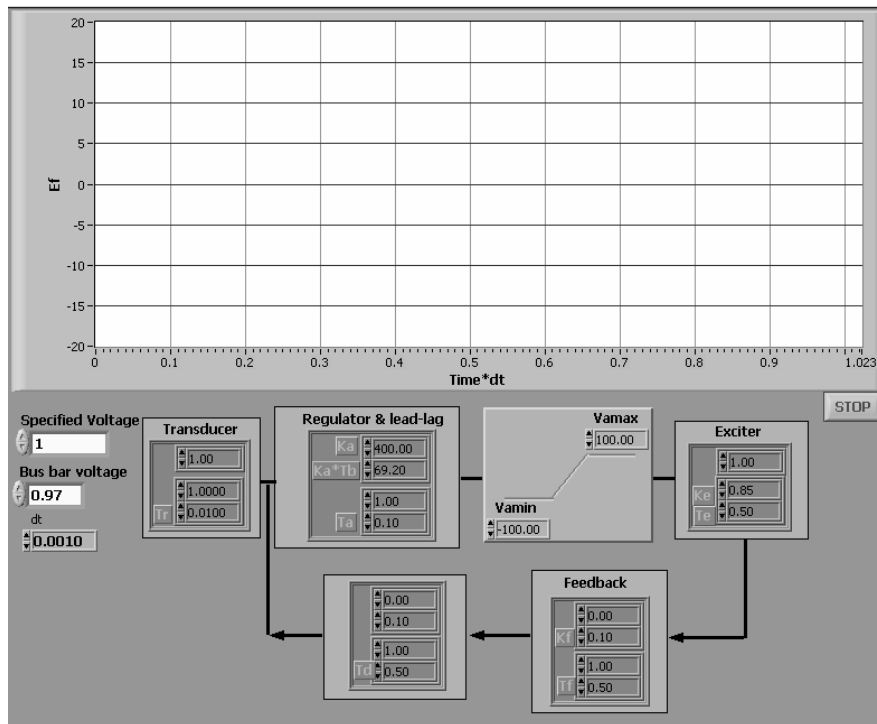

Fig.3 AVR instrument front panel

In table 1 we present a table for usual values for the parameters of the exciter systems used for simulations [1]:

Table1

Parameter	Usual values
$T_r$	very small, usually neglected
$K_a$	20-400
$T_a$	0.05s-0.2s
$K_e$	0.8-0.95
$T_e$	<1s
$K_f$	0.01-0.1
$T_f$	0.35-1s
$T_b$	-

We made a number of simulations to identify the response of the system on different changes of bus voltage and to adaptive control of the coefficients to reduce de transient time of the response and noise rejection.

We present below different step responses of the exciter system with values for coefficients those specified in the literature [2], and step response for the system with other values that we determined for better response (reduce transient time). The values are in relative units (excitation field).

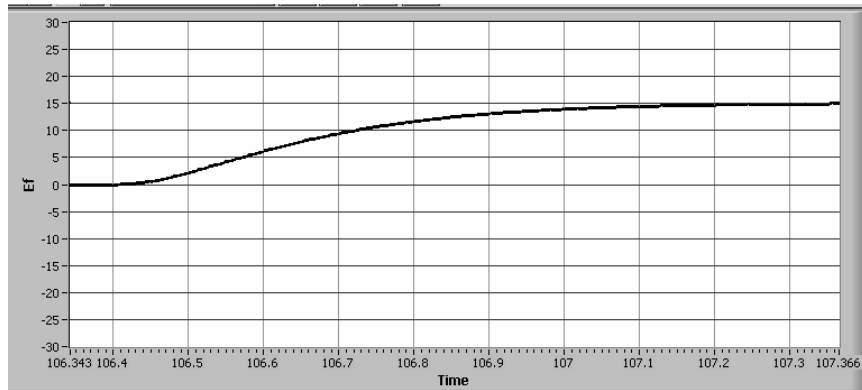

Fig.4 Response of the exciter for a step decrease of 15% of bus bar voltage

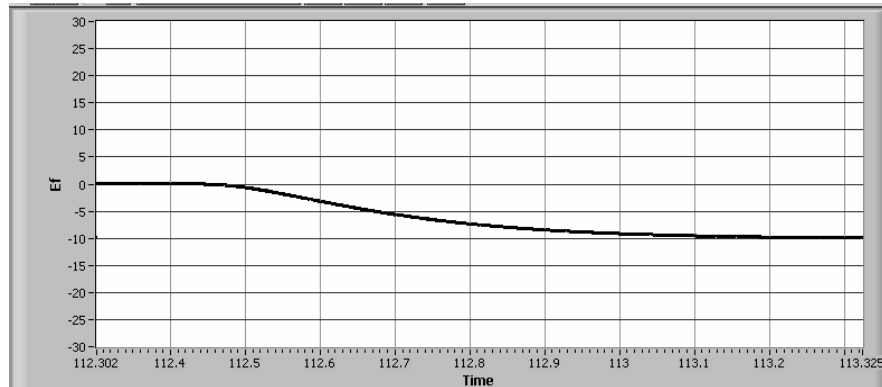

Fig.5 Response of the exciter for a step increase of 10% of bus bar voltage

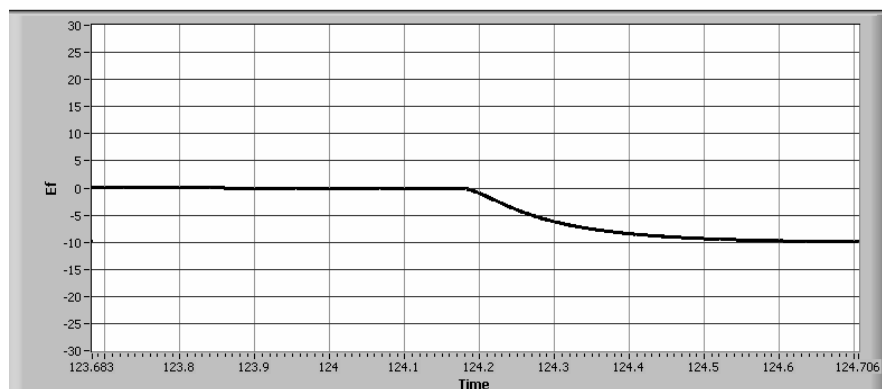

Fig.6 Response of the exciter for a step increase of 10% of bus bar voltage, modified coefficients

#### **4. CONCLUSIONS**

We presented a possible implementation of a real time exciter system with automatic voltage regulator for synchronous generators used in electric power generation. This implementation can be used for creating hardware in the loop exciter system for test, optimization of exciter systems and improving voltage regulation on existing power systems. Next step in to include adaptive control of the coefficients and limits.

#### **4. REFERENCES**

1. Jovica Milanovic (2002), Steady state and transient behavior of synchronous generators connected to distribution networks, IEEE presentation
2. J. Arrilaga, N.R.Watson (2001), Computer Modelling of Electrical Power Systems, John Wiley & Sons ltd.,369p